

UV COATER

ARGOS L380



Argos' new generation UV Coaters are built with one aim... creating the world's safest UV Coaters at the best possible price. Our goal is to provide customers with first in its class built UV Coaters with individually certified components. All development and manufacture occurs in Europe, respecting the strictest quality, health & safety guidelines.

All our UV-coating units are manufactured with only the highest quality, European components: digital ignitors - fully digital UV power supply - decroic filters to absorb IR radiation - special quartz filters (avoid burns of belts or paper), ...

Argos Solutions has more than 25 years of experience in the field of offset and digital printing. We specialize in the development and manufacture of pre and post coating machines, ideal for all digital and offset professionals.

Argos Solutions' Head Office in Belgium houses the European development centre, specialized in the development and manufacturing of high performance UV Coating systems for industrial as well as office applications.

NEW TYPE OF
UV COATER
WITH INNOVATIVE
CLOSED-COLD UV
LAMP SYSTEM

for improved operator safety and
working conditions.

Avoids burns of belts and media



Up to 50% energy savings!

with an ambient temperature of 25° Celsius and the possibility to run in standby mode in between 2 jobs, our newly developed UV head is the most economic system available. Compared to open lamp systems, we use decroic and quartz glass filters which reduce the OZON to a minimum. In standby mode, they lamp has about 50% less consumption (only in combination with feeder or inline with printer)

MACHINE DETAILS



LED button controls



Quick release roller system

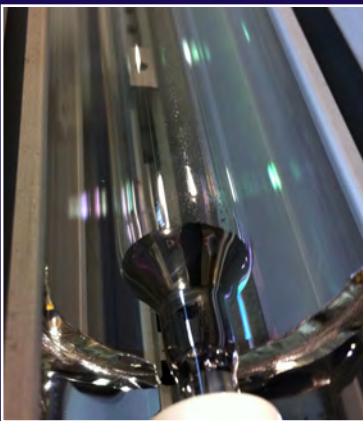

Closed UV lamp system with quartz glass to protect media from burn and decroic filters to absorb the oxidated air what makes the UV Coater real ozone free

Specifications L380:

MEDIA SPECIFICATIONS:

Min paper size	:	A6 (DIN format)
Max paper width	:	380 mm
Max paper length	:	660 mm (on delivery table)
Max paper length	:	1000 mm (no delivery table)
Min paper weight	:	150 gr
Max paper weight	:	450 gr (with feeder) up to 10 mm (without feeder)

MACHINE SPECIFICATIONS:

Min speed of belt	:	3 meters per minute
Max speed of belt	:	20 meters per minute
System	:	3 rollers with scraper
Infeed	:	manual by infeed plate with paperguides
Outfeed	:	length adjustable outfeed table from 500 to 800 mm
Rubber roller	:	Hannecard precision 65 shore 80 mm diameter
Metering roller	:	hardchrome with mirror polish 65 mm diameter
Pressure roller	:	hardchrome with mirror polish 65 mm diameter
Scraper	:	high quality negative metal scraper
UV Pumping	:	heavy duty peristaltic pump
Roller drive	:	belt drive system
Roller motor	:	Siemens CE/UL/TUV certified
Transport belt drive	:	belt driven system
Transport belt motor	:	Siemens CE/UL/TUV certified
Transport belt	:	German quality Teflon belt
General controls	:	B&R (Austria)

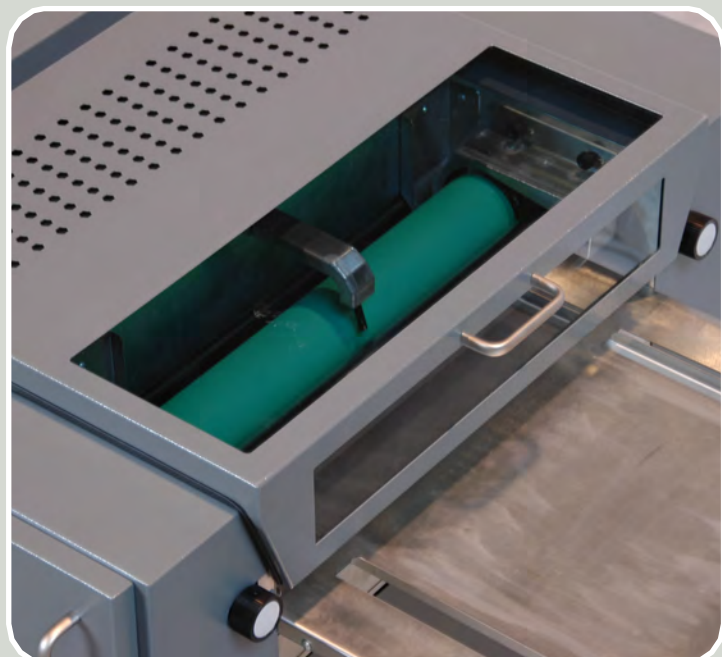

UV LAMP SPECIFICATIONS

Model	:	MAXWELL CI
Light Arc	:	420 mm
Maximum curing width	:	380 mm
Specific lamp power	:	100 W / cm
Standby mode	:	50 W / cm (only with feeder)
Installed lamp model	:	Ozon free 4219
Cooling fan	:	MS 20
Control cooling fan	:	by inverter, can variate if needed depending on the temperature
Ignition	:	electronic
Transformer	:	electronic/digital
Start up method	:	2 step transformer
Shutter	:	no
Compressed air	:	no
Ambient temperature	:	25° Celsius
UV Lamp system	:	closed lamp chamber in superficially treated extruded aluminum, resistant to energy floating Dichroic Technology with IR eliminator
UV lamp reflector	:	protected by IR filter in Quartz Glass to avoid burns (sheets cannot take fire)
UV radiation security	:	3 minutes
Start / stop cycle	:	

SAFETY STANDARDS

Machine Directive	:	2006/42/EC
Low Voltage Directive	:	2006/95/EC
Electromagnetic Compatibility Directive	:	2004/108/EC
Machinery Safety - basic terms	:	UNI EN ISO 12100-2
Technical principles	:	UNI EN ISO 12100-1
Principles of risk evaluation	:	UNI EN ISO 14121-1
Control parts linked to safety	:	UNI EN ISO 13850
Safety req. print & paper proc machines	:	UNI EN ISO 1010-1
Electromagnetic safety - el. equipment	:	CEI EN 60204-1
Electronic compatibility - Main regul.	:	CEI EN 6100-6-2
Industrial noise immunity	:	CEI EN 04.06.00
Safety labels	:	CE
Safety labels	:	UL in progress
Safety labels	:	TUV & SG in progress

Machines are manufactured and tested according to the following safety standards:

EN 1010-1:2004 / EN 1010-4:2004 + A1:2009 / EN 60204 1:2006 + A1:2009 / EN ISO 12100-1:2003 + A1:2009 / EN ISO 12100-2:2003 + A1:2009 / ISO 9001 manufacturing procedures / ISO 10001 quality procedures

All components, including UV lamp and power supply are individually certified following the latest safety & health regulations. The complete machine is RoHS compliant following the newest regulations of January 1st - 2013

OPTIONS



Fully automatic feeder with touch-screen programs, sheet counter and double sheet detector. Handles sheet-length up to 650mm.

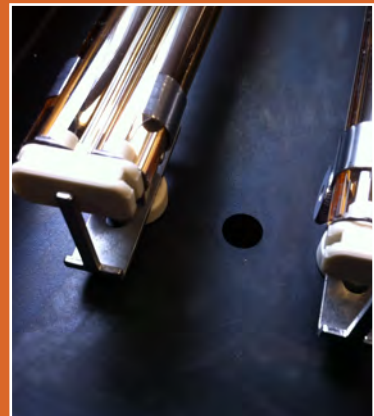

High German quality infra red lamps with gold reflector and digital temperature setting for wax toner based prints such as Canon, Konica Minolta, MGI or others...

Also available

Pile stacker at outfeed

Connection bridge to digital printers

Duplex turning station to connect 2 coaters to run duplex in 1 move

LED lamp system

Step 1 & 2 mode system

Photocell to avoid paper wrap with light weight paper

GUARANTEED EUROPEAN QUALITY

Working with **Argos Solutions**, a European Manufacturing company, guarantees all customers superior product quality as well as access to the highest standards required by European legislation.

The eye for detail: a careful selection of the choice of raw materials and the processes of manufacturing provide reliable and high quality results.

While the European printing industry can proudly point to the high standards of its products and production environment, we know very little about how seriously the same concerns and responsibilities are taken in non-European low-cost countries.

By choosing a European company, buyers are demonstrating that they are aware of the need to protect the environment and they can be certain that the working conditions in those companies are just and fair, an important principle for our society.

The entire EU industry regards sustainability as a guiding principle, and the industry has made great progress to ensure that its materials, processes and its practices are as sustainable as possible.

Intellectual Property Rights are widely respected in all European industries. We respect the creative energy that goes into the development of content and design of printed material and work within the relative standards.

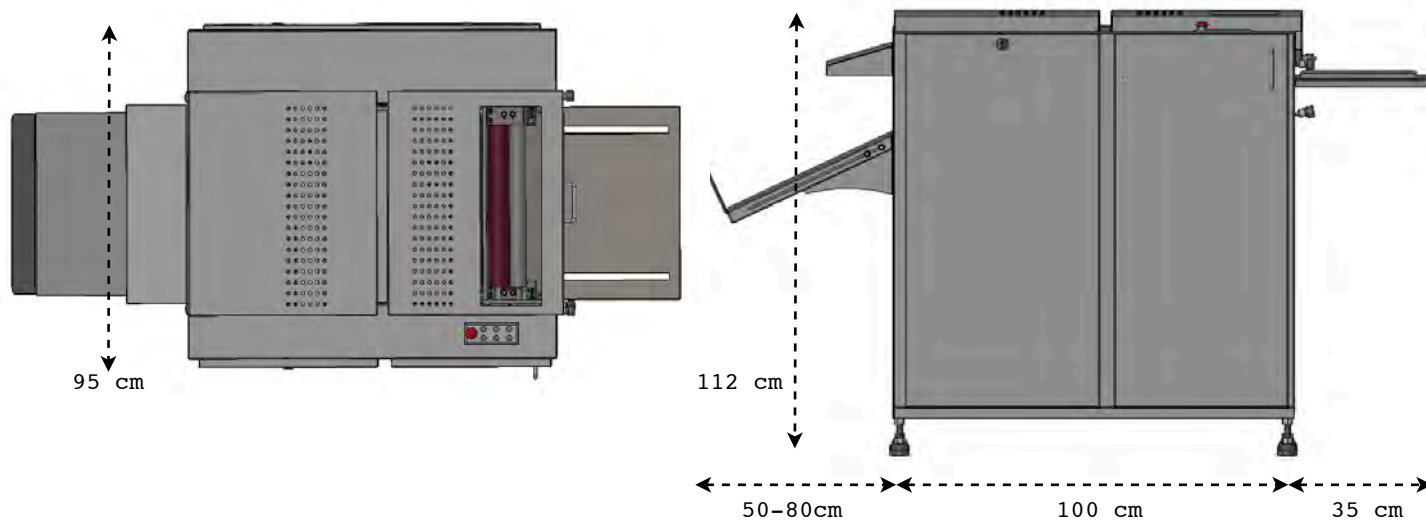

Headquarters / Europe

Argos Solutions
14, Rue des Foudriers
7822 Ghislenghien
tel: +32 2 808.13.99
fax: +32 2 808.13.98
www.argos-solutions.com
info@argos-solutions.com

Middle East

middle.east@argos-solutions.com

Africa

africa@argos-solutions.com

Russia

russia@argos-solutions.com

Pan Pacific

pan.pacific@argos-solutions.com

North America & Canada

north.america@argos-solutions.com

South America

south.america@argos-solutions.com

Asia

asia@argos-solutions.com